

# WOLF-7 PRO

NIGHT VISION GOGGLES

USER MANUAL

© 2025 AGM Global Vision, LLC. All rights reserved.

This documentation is subject to change without notice.

No parts of this manual, in whole or in part, may be copied, photocopied, translated, or transmitted by any electronic medium or in machine-readable form without the prior written permission of AGM Global Vision, LLC.

If you have questions that are not covered in this manual, or need service, contact AGM Global Vision customer support for additional information prior to returning a product.

## **AGM Global Vision, LLC**

**2407 E Interstate 30, Suite 100**

**Grand Prairie, TX 75050**

**Tel. 928.333.4300**

**support@agmglobalvision.com**

**www.agmglobalvision.com**

## **EXPORT INFORMATION**

Buyer acknowledges that all products supplied by AGM Global Vision, LLC are subject to U.S. export control laws, including, but not limited to, the Export Administration Regulations, the International Traffic in Arms Regulations, the International Economic Emergency Powers Act, and various U.S. embargoes and sanctions. AGM Global Vision products may not be exported, re-exported, or transferred contrary to U.S. export control laws. In particular, AGM Global Vision products may not be exported, re-exported, or transferred to prohibited countries, individuals, organizations, or entities, including but not limited to those individuals and entities listed on the List of Specially Designated Nationals and Blocked Persons administered or maintained by the U.S. Office of Foreign Assets Control ("OFAC"), the various lists maintained by the Bureau of Industry and Security of the Department of Commerce, and the U.S. State Department and Buyer represents and warrants that neither Buyer nor any of its officers, directors, or employees are on such lists. Distribution or resale by Buyer to such countries, individuals, organizations, or entities is expressly prohibited. Buyer has and will maintain a positive process to ensure compliance with this Section.

# LIST OF CONTENTS

TITLE	PAGE
Safety Summary	4
<b>SECTION 1. GENERAL INFORMATION</b>	<b>6</b>
1.1 System Description	6
1.2 Key Features	7
1.3 Standard Components	7
1.4 Optional Equipment	8
<b>SECTION 2. OPERATING INSTRUCTIONS</b>	<b>9</b>
2.1 Installation and mounting	9
2.2 Controls and Indicators	11
2.3 Operating Procedures	12
<b>SECTION 3. MAINTENANCE INSTRUCTIONS</b>	<b>15</b>
3.1 Cleaning Procedures	15
3.2 Troubleshooting	15
3.3 Preparation for Extended Storage	16
<b>SECTION 4. WARRANTY INFORMATION</b>	<b>17</b>
4.1 Warranty Information and Registration	17
<b>SECTION 5. SPECIFICATIONS</b>	<b>19</b>
5.1 Specifications	19

## SAFETY SUMMARY

- Read and follow all instructions
- Read all warnings
- Only use the attachments/accessories specified by the manufacturer
- All maintenance must be done by the manufacturer

### **WARNING:**

**This product contains natural rubber latex, which may cause potentially fatal allergic reactions! If you are allergic to latex, it is important that you strictly avoid exposure to products that contain it.**

### **WARNING:**

**The intensifier's phosphor screen contains toxic materials.**

Please note:

- If the intensifier tube breaks, be extremely careful to avoid inhaling the phosphor screen material. **DO NOT** allow the material to come in contact with your mouth, eyes, or any open wounds on the skin.
- If the phosphor screen material comes in contact with your skin, wash it off immediately with soap and water.
- If you inhale or swallow any phosphor screen material, drink a lot of water, induce vomiting, and seek medical attention as soon as possible.

### **WARNING:**

- When used in total darkness, the light from the unit's infrared (IR) illuminator is invisible to the naked eye. **However, the light can be detected by other Night Vision Devices (NVD).**
- To reduce the risk of detection by another NVD, avoid prolonged use of the IR illuminator.
- Light from the IR illuminator is more easily detected by other NVDs when used in fog, smoke, and rain. Avoid prolonged use of the IR illuminator in these conditions.
- Do not use contaminated eyecups. If it is contaminated, it must be replaced.

## **CAUTIONS:**

The Wolf-7 PRO night vision goggle system is a precision electro-optical instrument and requires careful handling. Please follow the below instructions for safe use:

- Do not disassemble the unit.
- Keep the unit clean; protect it from moisture, sudden temperature drops and shocks.
- Be careful not to touch the glass surfaces. If you leave finger-prints on, or contaminate the glass surfaces, use only clean and soft materials to clean it.
- Protect the unit from excessive lighting. Do not turn the goggles on in daylight with the front lens cap off. Do not point the goggles at the bright light source (a fire, car headlights, lanterns, street lamps, room lights, etc.).
- Do not test the device in daylight conditions even with the daylight filter/lens cap on for more than ten (10) minutes.
- Do not leave the unit in the ON position during breaks in operation.
- Remove the battery from the unit when it will be stored for more than 3 days. Failure to do so may damage the unit.

## **EQUIPMENT LIMITATIONS**

To avoid injuries and equipment damage from using the Wolf-7 PRO, carefully read and consider the following equipment limitations.

- The built-in IR illuminator is meant to provide additional illumination when needed, while viewing scenes at close distances (up to 3 meters).
- The equipment requires some night light (moonlight, starlight, etc.) to operate. The level of equipment performance depends upon the level of light.
- The amount of night light is reduced when passing through the clouds, while operating under trees, under the shadows of houses, etc.
- The device is less effective when peering into shadows and other darkened areas.
- The device is less effective in viewing through rain, fog, sleet, snow or smoke.
- The equipment will not “see” through dense smoke.
- Its protection system cuts off the image intensifier when ambient light level continues to exceed of 40 lux for 10 seconds or more.
- Under starlight conditions, low contrast environments (such as snow-covered territory, sandy deserts, large bodies of water or grassy hills) degrade visibility thereby disguising or masking changes in terrain.
- Under too low-light conditions the device loses some of the resolution it has under full moon conditions.

# 1 GENERAL INFORMATION

## 1.1 SYSTEM DESCRIPTION

The Wolf-7 PRO is a bi-ocular night vision goggle system that enables mobility in moonlit or starlit conditions. The Wolf-7 PRO provides bright and clear night vision images, even in the most trying conditions.

The Wolf-7 PRO includes a built-in short-range IR light source and offers a wide variety of accessories such as 3X, 5X and 8X magnification lenses for mid-to-long-range viewing, head or helmet mounts for hands-free operation, and additional, high-powered IR illuminator for long-range use. The unit features objective lens focus, eyepiece focus, and interpupillary distance adjustment.

Waterproof, rugged, light, and compact, the Wolf-7 PRO is the perfect device for a variety of tough operations. This includes driving, short-range surveillance, map reading, vehicle maintenance, and administering first aid.

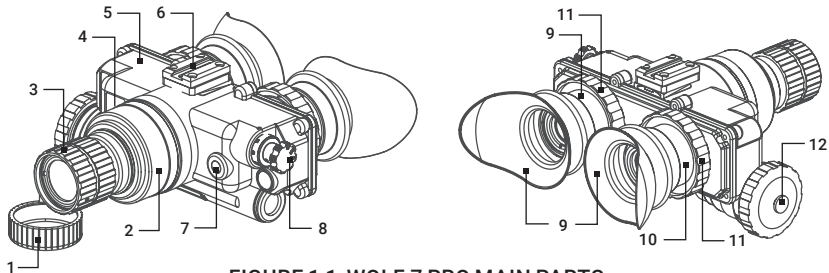

FIGURE 1-1. WOLF-7 PRO MAIN PARTS

TABLE 1-1. WOLF-7 PRO SYSTEM DESCRIPTION

ITEM	DESCRIPTION
1	Lens Cap
2	Objective Lens Assembly
3	Lens Focus Ring
4	Photoreceiver
5	Body
6	Mounting Rail

ITEM	DESCRIPTION
7	IR Illuminator
8	Function Switch Knob
9	Eyecup
10	Eyepiece Assembly
11	Diopter Adjustment Ring
12	Battery Cap

## 1.2 KEY FEATURES

- Compact, rugged design
- Waterproof
- Head or helmet-mountable for hands-free operation
- Ergonomic, simple, easy-to-operate controls
- Bright light cut-off
- Built-in Infrared illuminator
- Limited 3-year warranty

## 1.3 STANDARD COMPONENTS

The standard components of the Wolf-7 PRO are shown in Figure 1-2 and listed in Table 1-2. The ITEM column indicates the number used to identify items in Figure 1-2.

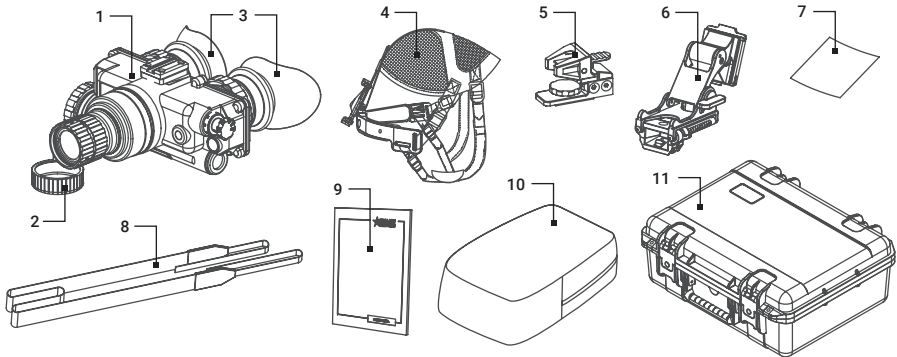

FIGURE 1-2. WOLF-7 PRO STANDARD COMPONENTS

TABLE 1-2. WOLF-7 PRO STANDARD COMPONENTS

ITEM	DESCRIPTION	QUANTITY
1	Night Vision Goggles	1
2	Lens Cap	1
3	Eyecup	2
4	Headgear Assembly	1
5	Transfer Adapter	1
6	Head/Helmet Mount	1
7	Lens Cloth	1
8	Neck Strap	1
9	User Manual	1
10	Soft Carrying Case	1
11	Hard Case for Storage/Transportation	1

## 1.4 OPTIONAL EQUIPMENT

The optional equipment of the Wolf-7 PRO is shown in Figure 1-3 and listed in Table 1-3. The ITEM column indicates the number used to identify items in Figure 1-3.

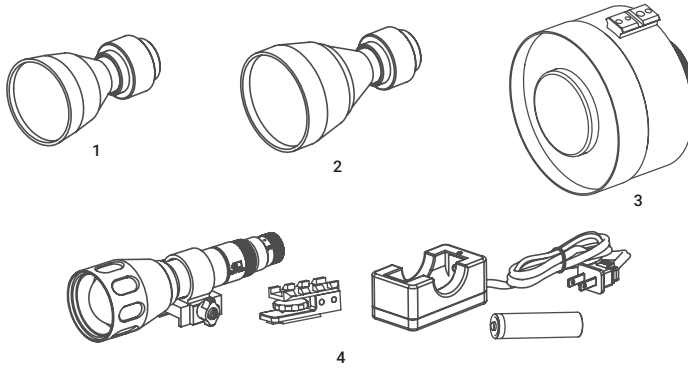

FIGURE 1-3. WOLF-7 PRO OPTIONAL EQUIPMENT

TABLE 1-3. WOLF-7 PRO OPTIONAL EQUIPMENT

ITEM	DESCRIPTION	PART NO.
1	AGM 3X Afocal Lens for Wolf-7 PRO	6102WP31
2	AGM 5X Afocal Lens for Wolf-7 PRO	6102WP51
3	AGM 8X Catadioptric Lens for Wolf-7 PRO	6101WP81
4	Sioux850 Long-Range Infrared Illuminator comes included with Mount, Adapter, Rechargeable Battery, and Charger	501SIUW850IR1

## 2 OPERATING INSTRUCTIONS

### 2.1. INSTALLATION AND MOUNTING

#### CAUTION:

To protect the intensifier tube when the sight is not in use or when it is being operated in daylight, keep the protective lens cap securely fitted over the lens.

#### 2.1.1 BATTERY INSTALLATION

To install batteries:

1. Turn the battery cap counterclockwise and remove it.
2. Verify that the O-ring is present. If it's not, replace it.
3. Following the polarity markings on the outside of the battery compartment, insert either two AA (1.5 V) batteries into the battery compartment, positive (+) end first (see Figure 2-1).
4. Secure the battery cap back on by placing it over the compartment and turning it clockwise. Verify that it is secure to ensure a watertight seal.

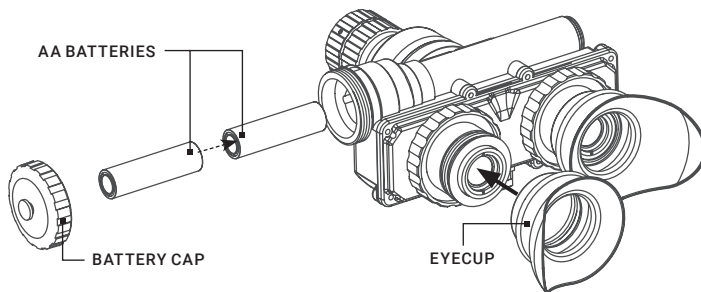

FIGURE 2-1. BATTERY AND EYE CAP INSTALLATION

#### 2.1.2 INSTALLATION OF THE EYECUPS

To install the eyecups (refer to Figure 2-1):

1. Carefully press each eyecup over the diopter cell retainer.
2. Rotate each eyecup into the proper viewing position. Adjust for the best fit. The eyecups must seal around your eyes and prevent the green light from showing outside of the eyepieces.

### 2.1.3 MOUNTING THE WOLF-7 PRO TO HEADGEAR ASSEMBLY

Adjust the headgear first before attaching the Wolf-7 PRO to it.

1. Loosen all the straps and place the headgear on your head.
2. Fit the headgear to your head size. Tighten the straps until the headgear fits firmly.
3. Remove the already adjusted headgear from your head.
4. Install the transfer adapter (Figure 2-2, 1) to mounting rail on the goggles body and fix adapter with the screw (2).

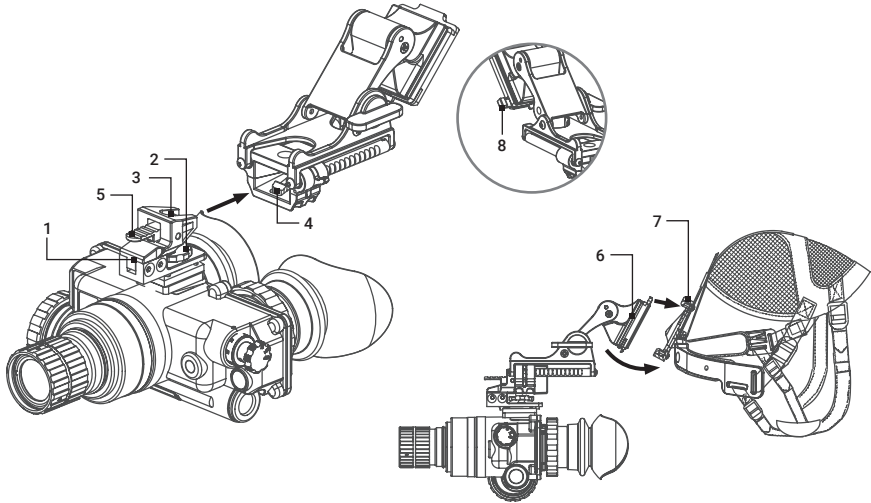

FIGURE 2-2. MOUNTING WOLF-7 PRO TO HEADGEAR ASSEMBLY

5. Align the prism of the transfer adapter (3) to the head mount socket (4). Push the parts together until the mating features engage.
6. Align the head mount (6) with the headgear bracket (7). Insert the top edge of the mount under the keeper on the headgear bracket and rotate it downward until the latch clicks into place. To release the mount from the bracket, press the release lever (8) on the side of head mount. To dismount the Wolf-7 PRO from the head mount, push down on the lever (5) and remove the unit.

#### NOTE:

The included head/helmet adapter can be used to attach the Wolf-7 PRO to headgear or helmet mount. The transfer adapter also can be used to attach the Wolf-7 PRO to standard PVS headset/helmet mounts.

## 2.1.4 OPTIONAL LENS INSTALLATION

The goggles can be used as a long-range viewer with an optional 3X, 5X afocal lens, or 8X catadioptric lens.

The 3X or 5X afocal lens can be installed directly onto the objective lens. Slip on the afocal lens over the end of the 1x objective lens of the goggles.

To mount the 8X lens, unscrew the existing 1X objective lens of the Wolf-7 PRO and screw an accessory lens in its place.

The 8X lens is equipped with a Picatinny rail for mounting a long-range IR illuminator and a socket for mounting the device on a tripod.

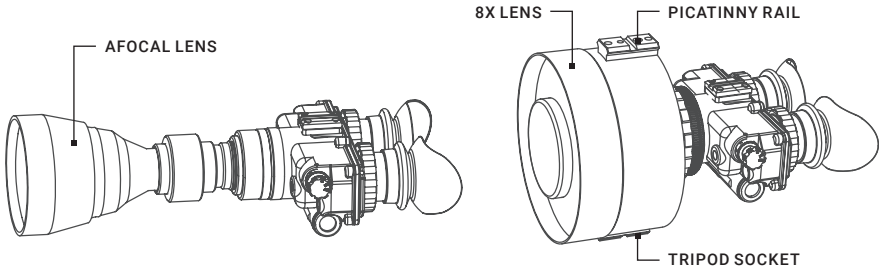

FIGURE 2-3. LENSES INSTALLATION

## 2.2 CONTROLS AND INDICATORS

### 2.2.1 CONTROLS AND INDICATORS

The Wolf-7 PRO is adjustable to accommodate different users and will correct for most differences in eyesight. The controls and indicators for the Wolf-7 PRO are shown or described in Figure 2-4 and Table 2-1.

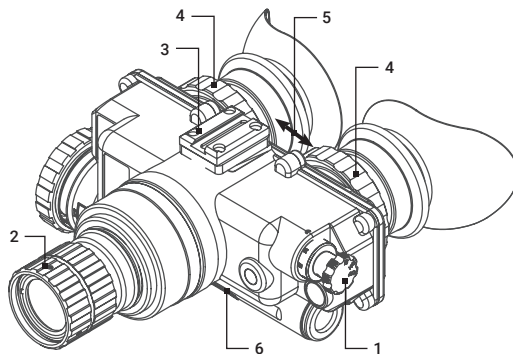

FIGURE 2-4. WOLF-7 PRO CONTROLS

TABLE 2-1. CONTROLS AND INDICATORS

ITEM	CONTROLS AND INDICATORS	FUNCTIONS
1	Function Switch Knob (OFF-ON-IR)	Controls goggles and IR light power ON or OFF. OFF: Same as system OFF. ON: The goggles are activated. IR: Turn switch clockwise to activate goggles and IR. When the IR is on, the LED in the eyepiece lights up.
2	Objective Focus Ring	Focuses the objective lens. Adjusts for the sharpest image.
3	Mounting Rail	Used to install the transfer adapter for mounting goggles on a headgear or helmet.
4	Diopter Adjustment Rings	Focuses the eyepiece lens for each eye (user will not need glasses). Adjusts for sharper image on intensifier screen.
5	Interpupillary Adjustment	Adjusts the distance between each eyepiece by sliding them together or apart, allowing for each eye to observe the entire field at the same time.
6	Battery/Polarity Indicator	The polarity icons are engraved into the Wolf-7 PRO battery housing, and show the proper orientation of the batteries.
7	LED ON Indicator (Not Shown)	When the IR is on, the red LED in the eyepiece lights up.
8	Power Indicator (Not Shown)	When the device is on, this LED in the eyepiece lights up.

## 2.3 OPERATING PROCEDURES

### 2.3.1 OPERATING PROCEDURES

1. Verify that the batteries are installed properly.

**CAUTION:**

Only operate the goggles in dark environments. If it necessary to operate the device in daylight, always cover the objective lens with lens cap. The pinhole at the centre of the lens cap will allow the user to check operational capabilities in daylight conditions.

2. Remove the lens cap.
3. Turn the function switch to the ON position. Power LED indicator in field of view will lights up. After a slight delay, a green or white glow will appear in the eyepiece of the unit.
4. Adjust the interpupillary distance by sliding the eyepieces together or apart so that each eye can observe the entire field of view at the same time. The eyepieces adjust independently.
5. Observe the scene. Adjust the diopter by rotating the adjustment rings.
6. Adjust the focus. Rotate the focus ring until the image is clear and sharp.

**NOTE:**

The sharpest image will only be visible when the objective lens and eyepiece lens are both properly focused.

If the bright light cut-off feature turns the device off, you need turn it back on manually after 1~2 minutes once the light in the surrounding environment decreases to an acceptable level, or the device is remitted to a darker area. To turn on the device again, set the operating switch to the OFF position and then turn it to the ON position.

### 2.3.2 IR ILLUMINATOR OPERATIONS

**NOTE:**

The built-in IR illuminator provides additional illumination (when needed) while viewing scenes or targets from a short distance (up to 3 meters).

To turn built-in IR Illuminator on, turn the operation switch from ON to the IR position. Red LED indicator in field of view will appear and indicate the IR illuminator is operating. Rotate the switch to ON position to deactivate the IR.

**NOTE:**

When you turn off the goggles, the IR illuminator will also turn off.

### 2.3.3 OPERATING UNDER CHANGING LIGHT CONDITIONS

If the ambient light level exceeds 40-100 Lux for more than 10 seconds, the automatic protective system will shut off the intensifier tube. If an operation must be carried out in changing light conditions, the user can shut down the protective system manually by closing the photoreceiver.

**CAUTION:**

DO NOT forget to open the photoreceiver after completing your mission.

### 2.3.4 HEAD-MOUNTED OPERATION

Perform the following procedures for head-mounted operation.

1. Put the head mount on per the instructions in Paragraph 2.1.4.

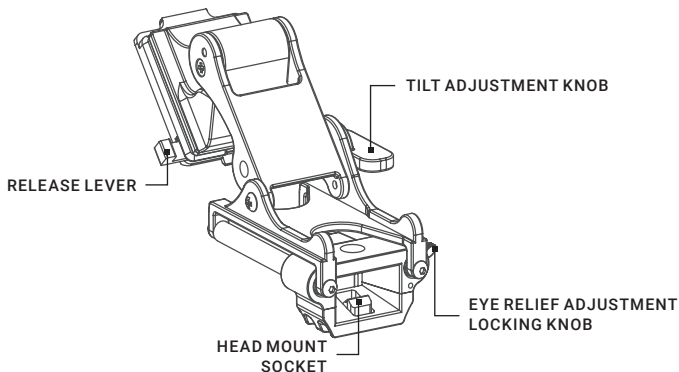

FIGURE 2-5. HEADMOUNT/HELMET MOUNT ADAPTER OPERATION

**NOTE:**

Before attaching the goggles, loosen the eye relief locking fixation knob and slide the head mount socket all the way forward; this will make it easier to align the goggles, eyecups, and eyepiece lenses with your eyes.

2. To set your eye relief, loosen the eye relief adjustment locking knob (Figure 2-5). Move the goggles back towards your eyes until the eyecups are comfortably sealed around your eyes. Tighten the locking knob.
3. Turn the goggles ON. Adjust the tilt using the tilt adjustment knob, until you obtain a comfortable viewing angle.
4. Adjust the vertical position of the goggles. Loosen the vertical adjustment locking knob of the head mount and move device up/down until the goggles is properly aligned with your eyes. Tighten the locking knob.
5. Adjust the diopter for the clearest view of the image intensifier screen.

**NOTE:**

Any adjustment for eye relief requires adjustment of the diopter.

6. While looking at an object, adjust the objective lens focus until the image becomes clear and sharp.
7. To flip the device up, place your hand under the goggles. Grasp and rotate them up and backwards until the latch clicks into place.
8. To flip the device down, grasp the goggles and rotate them down and forwards until the latch clicks into place.
9. To resume operation, turn the function switch to the OFF position, then to the ON position.

### **2.3.5 WOLF-7 PRO SHUTDOWN**

1. Turn the function switch to the OFF position. The green glow of the viewing area will fade to black.
2. Secure the lens cap over the objective lens.
3. If necessary, remove the unit from the goggle kit or helmet mount.
4. Unscrew the battery cap and remove the batteries. Replace the battery cap. Do not store the unit with the batteries installed.
5. Store the unit and all accessories in the case.

# 3 MAINTENANCE INSTRUCTIONS

## 3.1 CLEANING PROCEDURES

Wipe the housing with a damp cloth as needed.

### **CAUTION:**

**Do not use abrasives or solvents to clean the housing, lens, or the display window of the device. Do not use ammonia-based cleaning products to clean the lens. Doing so may damage the anti-reflective coating of the lens.**

The Wolf-7 PRO lens is designed for the harsh outdoor environment and has a coating for durability and anti-reflection, but it may require occasional cleaning. Optics can be damaged by improper cleaning. Avoid scratching the lens and/ or leaving fingerprints on the lens. Clean the lens according to the instructions below.

Do not use abrasive materials, such as paper towels or scrub brushes to clean lens, as this can scratch or otherwise damage the lens. Only clean when there is visible contamination on the surface.

### **Preferred Method for Cleaning the Lens**

Materials:

- Optical-grade cloth
- Pure water (deionized or other)
- Isopropyl alcohol (IPA)

Saturate a piece of the lens cloth with water and drape it over the lens. Let the surface tension of the water pull the cloth onto the lens surface. Drag the cloth across the lens surface. Repeat several times with different pieces of cloth.

Repeat the same steps using isopropyl alcohol instead of water. Drag the final piece of tissue over the lens several times to prevent pooling, which may leave a residue behind.

## 3.2 TROUBLESHOOTING

Table 3-1 lists the most common malfunctions that may occur with your device. Perform the tests, inspections, and corrective actions in accordance with the instructions given in the table.

This table does not list all the malfunctions that may occur with your device, or all of the tests, inspections, and corrective actions that may be necessary to fix them. If the equipment malfunction is not corrected by the suggested actions, or a problem occurs that is not listed in this table, please contact AGM Global Vision's Customer Support center or your retailer.

**TABLE 3-1. TROUBLESHOOTING**

<b>MALFUNCTION</b>	<b>PROBABLE CAUSE/ TEST/ INSPECTION</b>	<b>CORRECTIVE ACTION</b>
Goggles fails to activate.	Batteries are dead, missing or improperly installed.	Replace the battery or reinstall it correctly.
	Battery contact surfaces or contact springs are dirty or corroded.	Clean the contact surfaces with a pencil eraser and/ or alcohol and cotton swabs.
	Defective image intensifier.	Please contact Customer Support.
IR illuminator fails to activate.	Turn the IR illuminator on in a dark area. Visually estimate whether or not the observed scene is illuminated.	If the IR illuminator fails to activate, please contact Customer Support.
LED indicators fail to activate.	Visual inspection.	Please contact Customer Support.
Poor image quality.	Check objective lens or eyepieces focus.	Refocus the lens.
	Check for fogging or dirt on the lenses.	Clean the lenses as detailed in Part 3.1. If image quality is still poor, please contact Customer Support.
	Damaged optical components.	Please contact Customer Support
Light is visible around the eyecups.	Check the eye-relief distance.	Readjust for proper eye-relief distance.
	Check the eyecups resilience.	If the eyecup is defective, please contact Customer Support.
Focusing ring cannot be moved.	Check to see if the focusing ring is bent or broken.	If damaged, please contact Customer Support.
Eyepiece ring cannot be moved.	Check to see if the eyepiece ring is bent or broken.	If damaged, please contact Customer Support.

### **3.3 PREPARATION FOR EXTENDED STORAGE**

1. Unscrew the battery cap and remove the batteries from the goggles.
2. Inspect the battery compartment for corrosion or moisture. Clean and dry if necessary.
3. Replace the battery cap.
4. Remove the unit from the headgear or helmet mount, if installed.
5. Ensure that the goggles, accessories and case are free of dirt, dust, and moisture.
6. Place the goggles and accessories into the carrying case.

# 4 WARRANTY INFORMATION

## 4.1 WARRANTY INFORMATION AND REGISTRATION

### 4.1.1 WARRANTY INFORMATION

This product is guaranteed to be free from manufacturing defects in material and workmanship under normal use for a period of three (3) years from the date of purchase. In the event that a defect covered by the warranty below occurs during the applicable period stated above, AGM Global Vision, at its discretion, will either repair or replace the product; such action on the part of AGM Global Vision shall be the full extent of AGM Global Vision's liability, and the Customer's sole and exclusive reparation. This warranty does not cover a product if it has been (a) used in ways other than its normal and customary manner; (b) subjected to misuse; (c) subjected to alterations, modifications or repairs by the Customer or by any party other than AGM Global Vision without prior written consent of AGM Global Vision; (d) is the result of a special order or categorized as "close-out" merchandise or merchandise sold "as-is" by either AGM Global Vision or the AGM Global Vision dealer; or (e) merchandise that has been discontinued by the manufacturer and either parts or replacement units are not available due to reasons beyond the control of AGM Global Vision. AGM Global Vision shall not be responsible for any defects or damage that in AGM Global Vision's view are a result from the mishandling, abuse, misuse, improper storage or improper operation of the device, including use in conjunction with equipment that is electrically or mechanically incompatible with, or of inferior quality to, the product, as well as failure to maintain the environmental conditions specified by the manufacturer. This warranty is extended only to the original purchaser. Any breach of this warranty shall be enforced unless the customer notifies AGM Global Vision at the address noted below within the applicable warranty period.

The customer understands and agrees that except for the foregoing warranty, no other warranties written or oral, statutory, expressed or implied, including any implied warranty of merchantability or fitness for a particular purpose, shall apply to the product. All such implied warranties are hereby and expressly disclaimed.

### 4.1.2 LIMITATION OF LIABILITY

AGM Global Vision will not be liable for any claims, actions, suits, proceedings, costs, expenses, damages, or liabilities arising out of the use of this product. Operation and use of the product are the sole responsibility of the Customer. AGM Global Vision's sole undertaking is limited to providing the products and services outlined herein in accordance with the terms and conditions of this Agreement. The provision of products sold and services performed by AGM Global Vision to the Customer shall not be interpreted, construed, or regarded, either expressly or implied, as being for the benefit of or creating any obligation toward any third party of legal entity outside AGM Global Vision and the Customer; AGM Global Vision's obligations under this Agreement extend solely to the Customer. AGM Global Vision's liability hereunder for damages, regardless of the form or action, shall not exceed the fees or other charges paid to AGM Global Vision by the customer or customer's dealer. AGM Global Vision shall not, in any event, be liable for special, indirect, incidental, or consequential damages, including, but not limited to, lost income, lost revenue, or lost profit, whether such damages were foreseeable or not at the time of purchase, and whether or not such damages arise out of a breach of warranty, a breach of agreement, negligence, strict liability, or any other theory of liability.

### **4.1.3 PRODUCT REGISTRATION**

In order to validate the warranty on your product, the customer must complete and submit AGM Global Vision PRODUCT REGISTRATION FORM on our website ([www.agmglobalvision.com/customer-support](http://www.agmglobalvision.com/customer-support)).

### **4.1.4 OBTAINING WARRANTY SERVICE**

To obtain warranty service on your unit, the End-user (Customer) must notify the AGM Global Vision service department via e-mail. Send any requests to [support@agmglobalvision.com](mailto:support@agmglobalvision.com) to receive a Return Merchandise Authorization number (RMA). When returning any device, please take the product to your retailer, or send the product, postage paid and with a copy of your sales receipt, to AGM Global Vision's service center at the address listed above. All merchandise must be fully insured with the correct postage; AGM Global Vision will not be responsible for improper postage or merchandise that becomes lost or damaged during shipment. When sending product back, please clearly write the RMA# on the outside of the shipping box. Please include a letter that indicates your RMA#, the Customer's Name, a Return Address, reason for the return, contact information (valid telephone numbers and/or an e-mail address), and proof of purchase that will help us to establish the valid start date of the warranty. Product merchandise returns that do not have an RMA# listed may be refused, or a significant delay in processing may occur. Estimated Warranty service time is 10-20 business days. The End-user/Customer is responsible for postage to AGM Global Vision for warranty service. AGM Global Vision will cover return postage/shipping after warranty repair to the End-user/Customer only if the product is covered by the aforementioned warranty. AGM Global Vision will return the product after warranty service by domestic UPS Ground service and/or domestic mail. Should any other requested, required, or international shipping methods be necessary, the postage/shipping fee will be the responsibility of the End-user/Customer.

For service, repair or replacement, please contact:

**AGM Global Vision, LLC**

**2407 E Interstate 30, Suite 100**

**Grand Prairie, TX 75050**

**Tel. 928.333.4300**

**[support@agmglobalvision.com](mailto:support@agmglobalvision.com)**

**[www.agmglobalvision.com](http://www.agmglobalvision.com)**

# 5 SPECIFICATIONS

## 5.1 SPECIFICATIONS

TABLE 5-1. WOLF-7 PRO SPECIFICATIONS

ITEM	DATA
Magnification	1x (3x, 5x and 8x optional)
FOV	40°
Lens System	27mm; F/1.2
Diopter Adjustment	-5D to +5D
Exit Pupil	15 mm
Eye Relief	15 mm
Interpupillary Distance	57 - 73 mm
Focus Range	0.25 m to infinity
Infrared Illuminator	Yes
LED Indicators (in the FOV)	Power On; IR On
Bright Light Cut-Off	Yes
Automatic Brightness Control	Yes
Battery Type	Two 1.5V AA batteries
Battery Life (Operating)	- Up to 40hrs (IR off) - Up to 30hrs (IR on)
Operating Temperature Range	-40°C to +50°C / -40°F to +122°F
Storage Temperature Range	-50°C to +70°C / -58°F to +158°F
Waterproof	Yes (IP65)
Dimensions	183 × 132 × 58 mm / 7.2 × 5.2 × 2.3 in
Weight	510 g / 1.1 lb

**NOTE:**

All data is subject to change without notice.



## **AGM Global Vision, LLC**

### **MAIN OFFICE**

2407 E Interstate 30, Suite 100

Grand Prairie, TX 75050

Tel. 928.333.4300

[support@agmglobalvision.com](mailto:support@agmglobalvision.com)

[www.agmglobalvision.com](http://www.agmglobalvision.com)

### **EUROPEAN OFFICE**

#6 Andrey Lyapchev Blvd

Sofia, P.C. 1756

Bulgaria

Tel. +35.988.560.0326

[info@agmglobalvision.eu](mailto:info@agmglobalvision.eu)

[www.agmglobalvision.eu](http://www.agmglobalvision.eu)

[AGMglobalvision.com](http://AGMglobalvision.com)